



# RHEA 1a

D/A converter + preamplifier

User manual (EN version)



---

## INTRODUCTION

Rhea 1a is a digital-to-analog converter combined with a preamplifier function. It is a R2R converter without oversampling (NOS), capable of working in high resolution (Hi-Res). These converters are known for their natural, realistic presentation and non-fatiguing listening.

It is designed for music lovers who prefer to play via streamers or PC. Therefore, it contains a single USB input, which is implemented without compromising on quality, which we would have to do when using multiple digital inputs. Our USB input is galvanically isolated and then the I2S signal is reclocked and thus fed to the converters. This ensures the elimination of ground loops and enormous immunity from interference and jitter, which is very important especially when playing music from a PC or lower quality streamers.

Volume control is implemented by influencing the reference voltage of the converters. This means that no potentiometer is used in the analog signal path, nor is the digital side affected. This has a big impact on the playback quality. So you still play "bit-perfect". The volume control is either via a motorized rotary knob on the device itself, or via a minimalistic but robust remote control.

Each of the converter channels contains 4 times R2R 24 bit ladder, which brings even greater finesse and detail in the performance compared to using only one ladder.

The maximum output analog signal is greater than the standard line level, and therefore Rhea is able to directly drive power stages that have higher demands on the input signal level. Of course, you do not need to use the preamplifier function if you have your own preamplifier or line amplifier connected after the converter. Simply turn the volume control on Rhea to maximum.

Separate audiograde transformers are used in Rhea for the digital and analog sections. Only linear power supplies are used.

High-purity lead-free audiograde solder with 5% silver and 2% copper is used for soldering the components. This ensures perfect conductivity and durability of electrical connections and even higher transparency and details in the performance of music.

Our products are not mass-produced on a line. Each original piece is assembled component by component by our hands. Each electronic component is tested and measured before installation. After completion, a comprehensive functional testing and parameter measurement follow. Finally, each product is tested in our listening room to make sure that everything is as it should be.



---

## OPERATING INSTRUCTIONS AND SAFETY WARNINGS

1. Read all operating instructions and safety warnings before using the device.
2. Keep these operating instructions and safety warnings for future reference.
3. Some parts of this manual may be changed without prior notice to the user in order to improve product performance. The current version can always be found on our website.
4. The manufacturer reserves the right to make minor changes to the components used and internal wiring without prior notice, as long as these changes do not affect the function, reliability or declared technical parameters of the product. These changes do not affect the statutory rights of the consumer.
5. Do not apply excessive force to the device, throw it or hit it with objects.
6. The device must not be used by children. Keep it out of the reach of children.
7. Use in a temperate climate zone, do not use it in hot or humid conditions. Use the device in a well-ventilated, not enclosed space. The device may deteriorate, corrode, overheat or catch fire in an environment with a temperature below 0°C or in a closed space with a high temperature, such as a sauna. Moisture or liquid may also damage the surface of the product and its peripheral components.
8. Use the device only indoors.
9. The device should not be placed near water, such as near a bathtub, swimming pool, kitchen sink, etc. It should also not be exposed to dripping or splashing water and moisture, such as rain. If the device becomes damp or wet, do not turn it on and contact the service center. Unplug it from the power outlet.
10. Do not place objects containing liquids (vases, flower pots, etc.) where they can fall on the device or where they can spill onto the device.
11. Do not use chemical solutions (alcohol, thinner, solvents, etc.) or cleaning agents that could damage the surface or internal parts of the device to clean the device. For routine cleaning, use a clean, soft, dry cloth. In case of heavy soiling, lightly dampen a clean, soft cloth with a suitable cleaning agent for computer screens - the liquid must not get into the device. Always unplug the device from the power supply before cleaning.
12. Do not use accessories that are not recommended by the manufacturer.
13. Do not place the device on unstable surfaces. The device may fall, which may cause serious injury to children, adults or animals, as well as damage to the device. The device must be placed on a solid and level surface. Use only pads or stands recommended by the manufacturer. The device should be placed in accordance with the manufacturer's instructions and only accessories recommended by the manufacturer should be used.
14. Install this device at least 1 m away from devices that may emit radio interference (wireless routers, microwave ovens, etc.).
15. The device should be placed in a location that ensures proper air circulation. It must not be placed on a sofa, upholstered furniture, or other soft surfaces. It must not be covered during operation. This would prevent proper air circulation around the device.
16. Make sure that the device is away from sources of heat and open flames (direct sunlight, electric stove, candle, etc.).
17. There should be a minimum distance of 20 cm from other objects on all sides (except the bottom) around the device.



18. If the device starts to behave abnormally, becomes dangerously hot, or you start to smell smoke, immediately disconnect it from the power supply.
19. If the device shows visible signs of damage, do not connect it to the power supply.
20. The device must only be connected to the power source for which it is intended. This is indicated on the rear of the device next to the mains (IEC) socket.
21. Particular attention should be paid to the power (IEC) cable, which must be placed so that it is not likely to be walked on and is protected from mechanical damage.
22. Only use a certified (IEC) power cable for the region in which the device is used. It must include a protective earth connection and must also be correctly rated for the current. The same applies to any extension cables used.
23. If the device is not to be used for a long period of time, the power cable should be disconnected from the mains. Also disconnect it during lightning storms. Always disconnect it when the power switch is off.
24. Before connecting the power cable and turning on the device, connect the audio cables first.
25. For trouble-free use, you must first connect the power cord to the device and only then turn on the power switch.
26. The device may only be connected to a power outlet with a protective earth connection.
27. When replacing fuses, the device must be switched off and the power cord disconnected.
28. The device may only be repaired by a qualified service if:
  - a. The power cord is damaged.
  - b. The device has fallen into water or water has been spilled on it.
  - c. The device has been exposed to rain.
  - d. The device is not working properly.
  - e. The device has fallen to the ground or is otherwise mechanically damaged.
29. All repairs must be entrusted to a qualified service.
30. Do not disassemble, modify or repair the product yourself. Doing so will put your health and life at risk. If a malfunction occurs as a result, contact a qualified service center.
31. Use the device according to the operating instructions and safety warnings and in accordance with the user manual.

**The manufacturer declines any responsibility if these operating instructions and safety warnings are not followed. To avoid electric shock, do not expose the DAC Rhea 1a to rain, water or moisture!**



## DELIVERY CONTENTS

Shipping packaging

D/A converter Rhea 1a

Remote control (requires CR2032 battery, device is supplied without this battery)

## DESCRIPTION D/A CONVERTER RHEA 1a

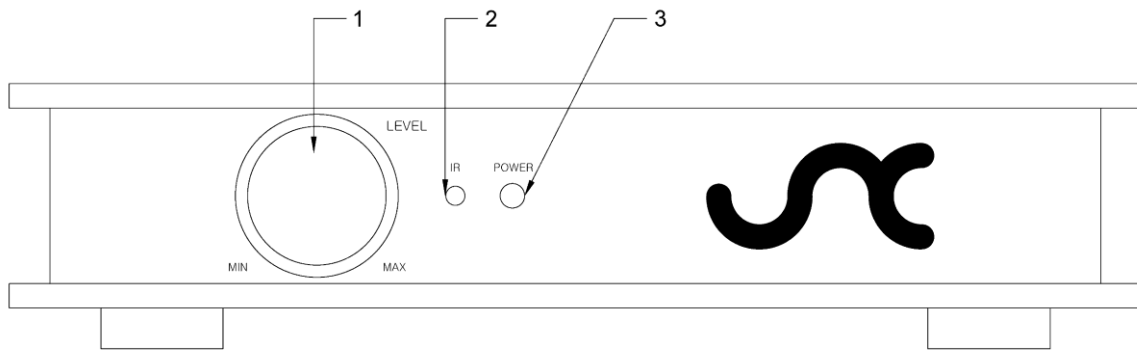

- 1) **Volume control:** Turning clockwise increases the output signal level to the maximum level. Turning counterclockwise decreases the output signal level to the minimum level, which is approximately -60dBFS. This means that the volume control cannot reach absolute zero, but only approach it. You can turn this control manually or using the remote control.
- 2) **IR signal receiver:** Receives the signal from the remote control. To control the volume with the remote control, the remote control must be pointed at this area and there must be a direct line of sight between the remote control and the IR receiver.
- 3) **Power on indicator:** When lit, it indicates that the device is on.

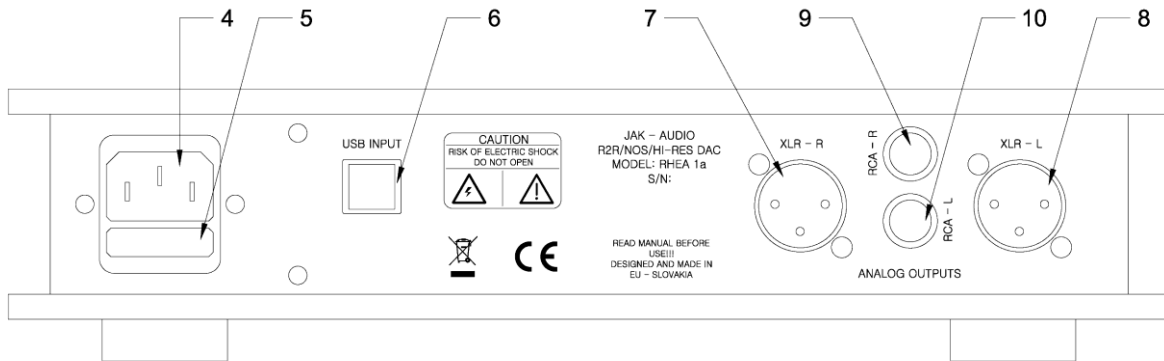

- 4) **Mains socket:** Connection of the mains (IEC) power cable, which must include a protective earth connection. The device must only be connected to the power supply for which it is intended. This is indicated on the rear of the device next to the mains (IEC) socket.
- 5) **Mains fuse:** The fuse must be replaced with the device switched off and the mains cable disconnected. It must be replaced with the type of fuse indicated on the label next to the mains socket.
- 6) **USB audio input:** Connection of a music source.
- 7) **Audio output XLR-R:** Balanced audio output right channel.
- 8) **Audio output XLR-L:** Balanced audio output left channel.
- 9) **Audio output RCA-R:** Unbalanced audio output right channel.
- 10) **Audio output RCA-L:** Unbalanced audio output left channel.

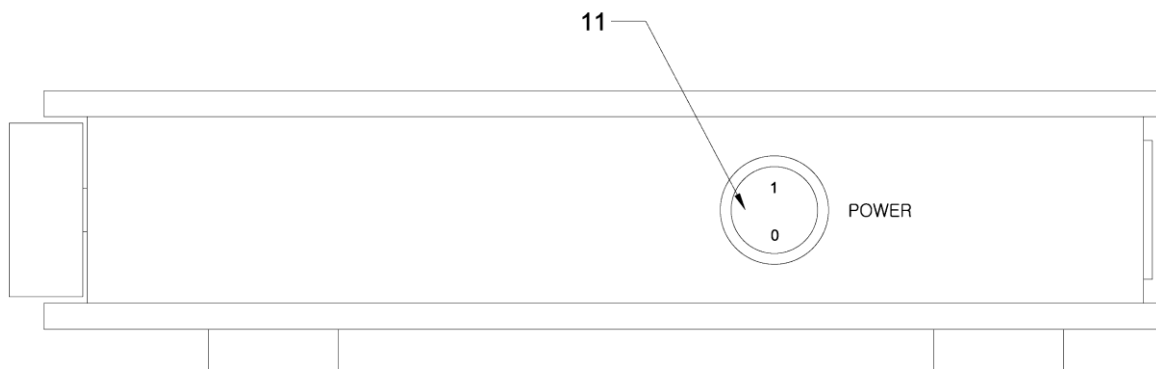

- 11) **Main power switch:** Used to turn the device on and off. The Rhea 1a D/A converter does not have a standby mode, meaning that it has no power consumption when the switch is off. To avoid unpleasant sound in the speakers when turning on your audio system, you must first turn on the D/A converter and only then the following components (preamplifier, amplifier, etc.).



## DESCRIPTION REMOTE CONTROL

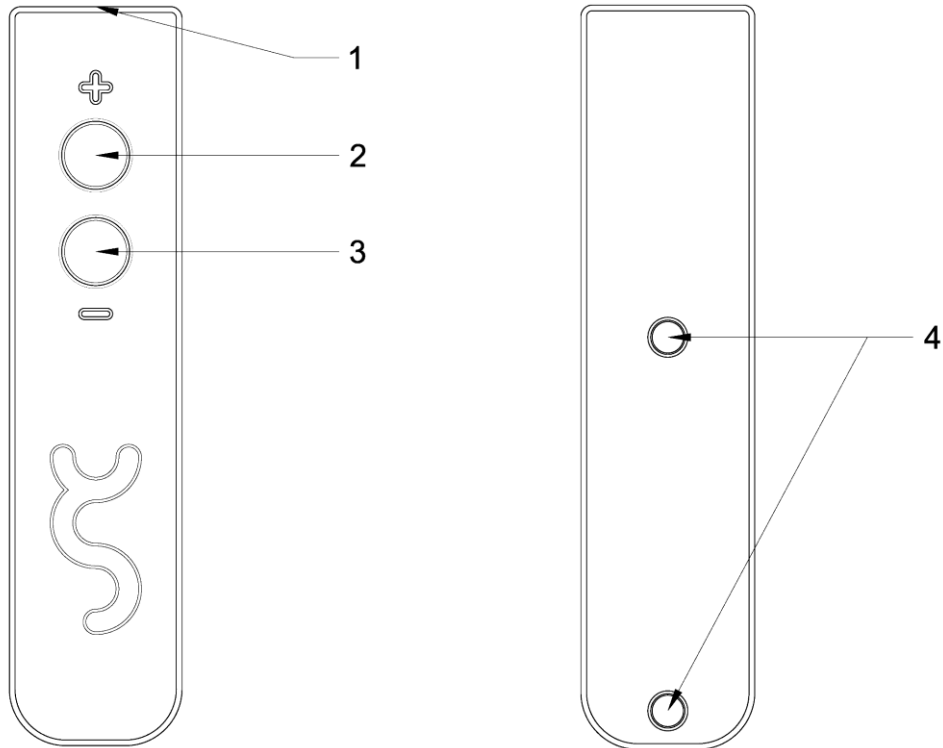

Left view of the front cover, right view of the back cover.

- 1) **IR signal transmitter:** Transmits a signal to control the D/A converter. Do not expose it to direct sunlight or strong light sources.
- 2) **Volume up button:** Press to increase the volume with gradual acceleration.
- 3) **Volume down button:** Press to decrease the volume with gradual acceleration.
- 4) **Screws for disassembling the remote control:** Unscrew these screws to replace the battery. Turn the remote control with the screws facing upwards and the buttons facing downwards. Then remove the back cover of the remote control by lifting it upwards. This will expose the printed circuit board. Carefully remove the printed circuit board from the front cover of the remote control (press the volume buttons gently and the printed circuit board will pop out). Avoid touching the electronic components, as this may damage the remote control. Be careful not to bend the legs of the IR signal transmitter. Then remove the old battery from the battery holder. Insert the new battery into the holder with the “+” pole facing up. Insert the circuit board into the front cover of the controller. Cover with the back cover and screw it on.



---

## TECHNICAL INFORMATION

Converter type:	R2R / NOS / Hi-Res / Balanced
Technology:	FPGA + R2R (integrated circuit)
Supported audio format:	PCM (For DSD, convert to PCM in your player)
Bit depth:	24 bit
Sampling frequency:	up to 384 kHz
Harmonic distortion @ FS:	0.006%
Noise floor (ref. FS):	-140 dB
Crosstalk:	-140 dB
Volume range:	-60 dBFS to 0 dBFS (completely zero volume cannot be achieved)
Frequency response:	
44.1 kHz sampling:	1 Hz: -0.8 dB to 20 kHz: -2.5 dB
192 – 384 kHz sampling:	1 Hz: -0.8 dB to 65 kHz: -3 dB
Outputs:	2 x RCA / 2 x XLR (stereo)
Maximum output level:	RCA: 2.8 V / XLR: 5.6 V (RMS)
Output impedance:	RCA: 25 Ohm / XLR: 50 Ohm
Input:	1 x USB (galvanically isolated, reclocked)
Supported operating systems:	Linux, MAC OS, Windows XP and above (driver required)
Transformers:	2 x 20 VA toroidal audiograde transformer
Sources:	linear
Power consumption:	6 W
Power supply:	230 V / 50 – 60 Hz / 9 VA
Solder:	audiograde (5% silver, 2% copper)
Remote volume control:	IR
Casing:	black sandblasted anodized aluminum and highly polished stainless steel
Weight:	4 kg
Dimensions:	278 mm (width) x 258 mm (depth) x 55 mm (height without feet)



Packaging: 1 x DAC, 1 x remote control

## NOTE

At least 60 hours of music playback is required to achieve full audio potential.

Please download the USB audio driver from our website.

## WASTE SEPARATION

Waste Electrical and Electronic Equipment Directive – European Union Regulation 2012/19/EU on the separate collection of waste.

This device must not be disposed of as unsorted municipal waste. Hand it over to a collection point for the recycling and disposal of waste electrical and electronic equipment. Correct disposal of waste will not cause negative impacts on the environment and human health. You will help to protect the environment.

## WARRANTY CONDITIONS

The warranty period for this appliance is 24 months, calculated from the date of purchase. The warranty is only valid if the original proof of purchase and the confirmed warranty certificate can be presented. The warranty covers material and workmanship defects, but does not cover misuse contrary to this manual, unauthorized modifications, repairs other than directly at JAK-AUDIO and external causes such as natural events, power supply abnormalities, etc. The manufacturer assumes no liability for damage caused by failure to comply with this instruction manual. Modification or changes to any part of the product by unauthorized persons relieve the manufacturer of any liability beyond the statutory rights of the customer.

**Attention! There are no user-serviceable parts inside your Rhea 1a D/A converter!**

## SERVICE

If you encounter a problem that you cannot alleviate or identify, please contact your dealer for further advice. Please note that the Rhea 1a is difficult to disassemble and even more difficult to reassemble. This is due to the stainless steel casing that is housed in grooves in the bottom and top panels. Disassembly and assembly may cause visual damage to the device, which is not covered by the warranty. For this reason, we recommend that you entrust the service to JAK-AUDIO.



## COPYRIGHT, TRADEMARKS

Windows® is a trademark of the Microsoft group of companies. Mac® and Mac OS® are trademarks of Apple Inc.

## EUROPEAN COMMUNITY DIRECTIVES

This product is designed and manufactured in accordance with the applicable laws of the European Community.

